



Porcelain Pavers Installation Guide

— On-Grade and Elevated Applications

Table of Contents

- Pre-Installation Considerations** 03
- Handling Pavers** 04
- Cutting And Laying Pavers** 04
- Joint Infilling** 05
- Legal Disclaimer** 05
- Installation Options** 06
 - On-grade** 07
 - On Sand With Compacted Gravel Base 08
 - On Gravel - Permeable 09
 - On Gravel Mixed With Cement 10
 - Over Concrete Base Set In Sand 11
 - Over Concrete Base With Thinset Or Adhesive 12
 - Over Grass 13
 - Elevated-Installation** 14
 - Stackable Rubber Pads Over Hard Surfaces 15
 - Adjustable Height Pedestals Over Hard Surfaces 16
 - Pedestal Supported Rail System 17
 - Placement & Layouts 18
- Special Considerations For Elevated Decking Installations** 19

Pre-Installation Considerations



Before commencing any work, installers and contractors must ensure that any substructures or substrates on which the pavers will be laid meet all requirements in terms of stability, compaction and load bearing capacity. To ensure good drainage, solid substrates should have a minimum slope of 1.5%.

For structural applications with $\frac{3}{4}$ " thick porcelain pavers, designers, architects, specifiers and/or clients should always make a careful assessment of the project requirements, including the nature of the site, the intended use and weight loadings in relation to technical characteristics of the pavers.

All local regulations, especially those concerning the action of the wind, structural load, fire and seismic conditions, must be complied with.

With elevated deck applications where pavers are supported on pedestal systems, the shock resistance of porcelain pavers should also be considered to avoid the

risk of damage or injury. Despite the intrinsic density and stiffness of porcelain pavers, pavers could potentially break if a heavy object is dropped from a significant height. Where hard and heavy objects are likely to be used or where floor heights are greater than 4", appropriate reinforcement should be used under the pavers, such as glued glass fiber mats, metal trays or fiberglass grating panels.

Failure to comply with all local laws, regulations and our installation recommendations may lead to improper use of the product and could cause serious damage or injury to persons and property.

For additional support or other technical information on the installation of porcelain pavers, please contact Archatrak at solutions@archatrak.com.

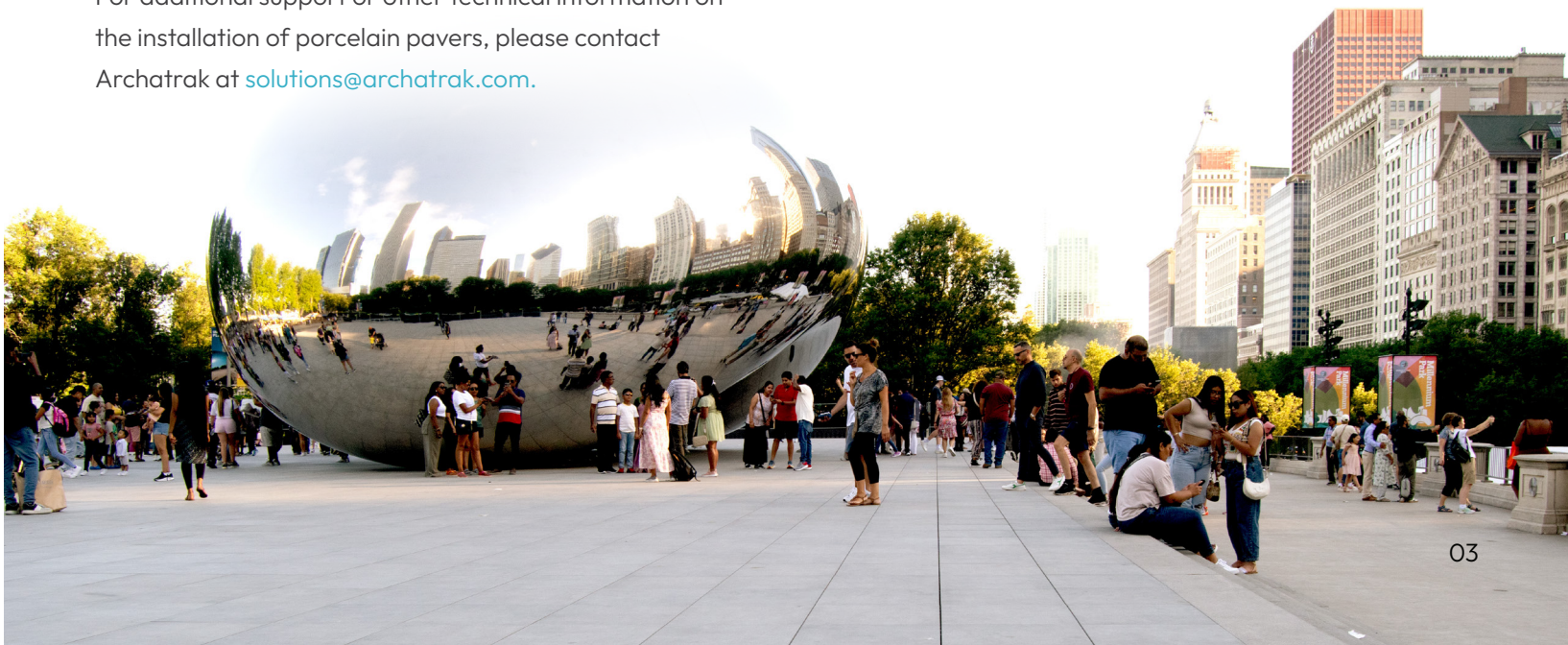

Handling Pavers



- Porcelain pavers are typically supplied on plastic wrapped pallets with pavers packaged in protective cardboard cartons. To avoid damage to the pavers, do not remove the pavers from the protective cartons until they are ready for installation.
- Avoid handling multiple pavers or loose pieces of pavers together as this increases the possibility of chipping.
- Avoid leaving un-used boxed pavers exposed to weather to ensure the integrity of the protective cardboard cartons.
- A paver clamp or vacuum lifter makes it easier to handle pavers, and can be used for both installation and removal of pavers.
- A pair of sturdy gloves is highly recommended when handling pavers.

Cutting and Laying Pavers



- Use a wet saw fitted with a diamond blade designed for cutting porcelain, which will provide a smoother cut, reduce dust, and avoid chipping. Bridge saws with a 10" blade are recommended. In general, thinner blades are less prone to chipping along the cut line.
- Never compact porcelain pavers with a plate compactor.
- Always compact and level sand beds before installing porcelain pavers in sand set installations.
- Porcelain pavers should not be installed with porcelain-to-porcelain contact. 3/16" min. spacers are recommended for most installations.

Joint Infilling

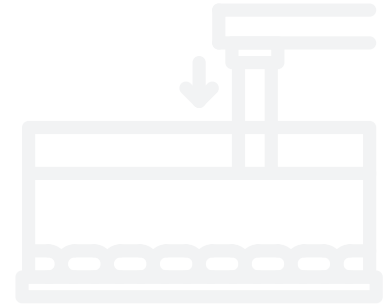

In sand or gravel set installations, several options can be considered for infilling joints.

Traditional Sand

Dry sand offers good mechanical properties and will partially absorb any movement between pavers. However dry sand filled joints will not prevent growth of grass or other plant material, nor prevent insects such as ants from nesting and tunneling under the pavers. Under some circumstances, water could filter into the surface below, turning to ice in cold weather and lifting the pavers. In very windy locations, on slopes or where there is heavy rainfall, the sand in the joints can become depleted due to erosion.

Method: Dry sand is swept into the open joints until they are completely filled. Excess sand is then swept away.

Cement Blended Sand

Joints with cement blended sand have excellent mechanical properties and are more durable than sand or polymeric sand. Weeds will not grow in joints filled with a cement sand mix and insects and ants cannot build nests. However, with cement blended sand joint filling, the paving will be totally impermeable to water; once the joints have been filled, they will not be subject to erosion and should remain intact over a considerable time.

Method: Dry cement blended sand (typically 3 parts sand to 1 part cement) is swept into the open joints until they are completely filled. Excess cement blended sand is then swept away.

It is extremely important that all excess sand and cement dust is swept from the surface as any residual material could discolor the surface. After the joints are filled and excess cement blended sand is swept away, spray the paved area with a light mist of water to enable curing of the cement.

Polymeric Sand

Polymeric sand is composed of a mixture of polymer binders and dry sand. Once the sand is wet, it hardens and becomes quite solid. It is equally effective on both flat surfaces and sloping ground. The joints have excellent mechanical properties, absorbing movement between pavers.

Weeds should not grow in joints filled with polymeric sand and insects and ants should not be able to make nests. The paving is essentially impermeable, and the joints remain intact, unaffected by erosion from wind or water.

Method: Polymeric sand is swept into the open joints until they are completely filled. It is extremely important that all excess polymeric sand is swept from the surface as any residual material could discolor the surface. After the joints are filled, spray the paved area with a light mist of water to enable the process of polymerization. Spray again 5-10 minutes later. In dry weather, the polymerization process will be complete in a few hours so the paving becomes serviceable in about 24 hours.

Grout Filled Joints

Cement based grout offers excellent mechanical properties, absorbing any movement between the pavers. It also helps to distribute the surface load, ensuring maximum stability. Weeds will not grow in joints filled with cement grout and insects and ants cannot make their nests. The paving is totally impermeable and the joints remain intact over time.

Method: After the mortar used to lay the pavers is cured and dry, spread grout into the joints using a rubber blade, making sure the joints are completely filled. Pass the rubber blade diagonally across the joints to remove any excess grout. Immediately after filling the joints, use a damp sponge to remove residue on the surface of the pavers. After the grout is dry, remove any residue with a water and buffered acid solution. Finally, rinse well with water.



Legal Disclaimer

The information and recommendations in this document are for informational purposes only. The installation diagrams and procedures are to be considered as indicative only and have the sole purpose of illustrating various types of applications and the means of achieving a specific installation in a workmanlike manner. In no way should it be construed that the information presented in this brochure overrides any regulations, standards or procedures that may apply to installation of unit paving in any specific configuration or locality.



Installation Options

On-Grade

INSTALLATION - ON GRADE APPLICATIONS

On Sand with Compacted Gravel Base

Dry laying on sand is recommended for non-vehicular applications such as garden landscaping, patios, courtyards, walkways and terraces.

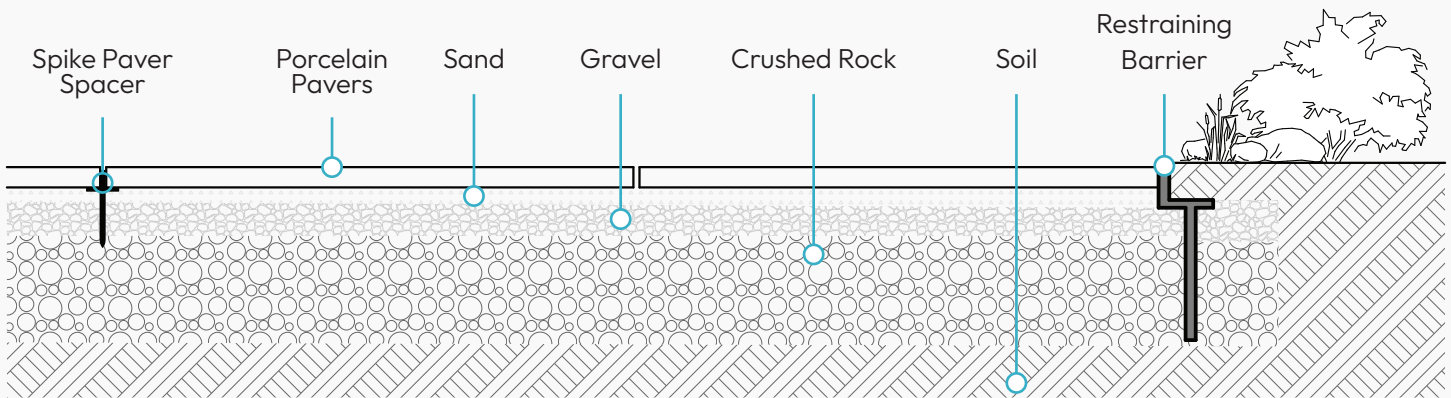

1. After defining the area to be excavated, mark the perimeter using wooden or steel marker posts connected by a string. Note that the excavated area should be extended on all sides by approx. 6"-8" to ensure stability at the outer edges of the paved area.
2. Remove the soil inside the marked area using a shovel or excavator. The depth of excavation will depend on several factors including the anticipated loading, the drainage capacity of the soil and the soil conditions in general.
3. Using a rake or shovel, level the excavated area and ensure there is at least 2% slope for good drainage. Compact the soil with a vibro compactor.
4. A restraining perimeter wall should be installed prior to laying the gravel/sand bed unless it is in direct contact with a footpath, wall or an existing edge that is sufficiently rigid. The perimeter wall should be fixed to the ground with mechanical fixing devices or constructed as a solid barrier using poured concrete.
5. Place a sheet of geotextile fabric on top of the compacted soil to prevent the soil from mixing with the gravel.
6. Fill the excavated area with $\frac{3}{4}$ " stone screenings to a thickness of 8" - 12", depending on the planned loading.
7. Add a further layer of $\frac{3}{8}$ " gravel to a thickness between 4"-8". Compact the two layers and then level, ensuring there is a slope of approx. 2%.
8. Place a sheet of geotextile fabric on top of the compacted gravel to prevent the gravel from mixing with the sand.
9. Fill the area with sand to a thickness of between $\frac{3}{4}$ " and 2" and compact with a vibro compactor.
10. Level the surface by sliding a wood or steel board placed on two parallel runners across the entire area, again ensuring there is a slope of approx. 2%.
11. Taking care not to disturb the sand bed, lay the pavers using $\frac{3}{16}$ " min. spacers. Carefully tap the pavers with a rubber mallet to ensure they are not rocking on the sand bed and that they are level with each other.

Installation - On Grade Applications

On Gravel - Permeable

Dry laying on gravel over a concrete base is recommended for applications such as garden landscaping, patios, courtyards, walkways and terraces. This method enables good drainage via the joints between the slabs and permits drainage of water through the gravel.

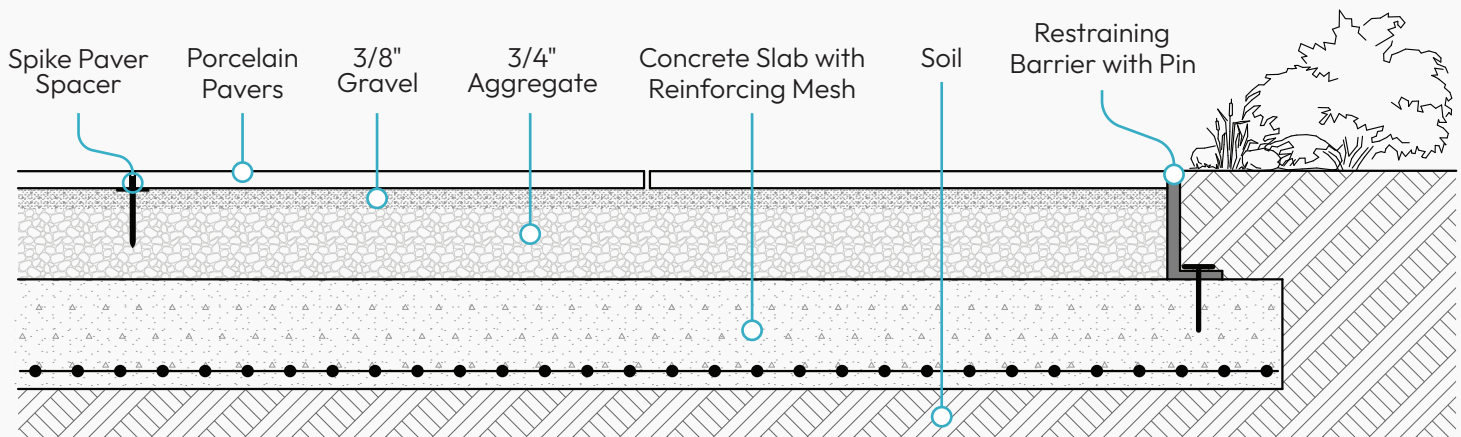

1. After defining the area to be excavated, mark the perimeter using wooden or steel marker posts connected by a string. Note that the excavated area should be extended on all sides by approx. 6"-8" to ensure stability at the outer edges of the paved area.
2. Remove the soil inside the marked area using a shovel or excavator. The depth of excavation will depend on several factors including the anticipated loading, the drainage capacity of the soil and the soil conditions in general.
3. Using a rake or shovel, level the excavated area and ensure there is at least 2% slope for good drainage. Compact the soil with a vibro compactor.
4. Pour a base layer of concrete. First, lay welded reinforcing mesh over the area and pour a layer of concrete aggregate of thickness 4"-8" depending on the anticipated loading. The slab should be laid with a slope of 2-5% for drainage.
5. After the concrete has set, lay a waterproof sheet over the concrete.
6. To improve drainage, a honeycomb mat may be placed over the waterproofing sheet.
7. Install a curb or restraining edge around the entire perimeter unless it is in direct contact with a footpath, wall or an existing edge that is sufficiently rigid. The perimeter wall should be fixed to the concrete base with mechanical fixing devices. If possible, at least half the height of the restraining edge should be covered with soil on the external side of the paved area.
8. Lay a 4"-12" thick layer of 3/4" aggregate, depending on the intended use, on top of the honeycomb mat. For greater stability, mix gravel with 5% cement and a small amount of water.
9. Add a final bedding layer of approx. 3/8" gravel to a thickness of 2" and compact with a vibro compactor.
10. Level the surface by sliding a wood or steel board placed on two parallel runners across the entire area, ensuring there is a slope of approx. 2%.
11. Taking care not to disturb the gravel bed, lay the pavers using 3/16" min. spacers. Carefully tap the pavers with a rubber mallet to ensure they are not rocking on the gravel bed and that they are level with each other.

Installation - On Grade Applications

On Gravel Mixed with Cement

Dry laying on gravel mixed with cement can be used for applications such as garden landscaping, patios, courtyards, walkways and terraces for a more stable surface than a completely dry installation, but it will not be possible to easily lift and replace pavers.

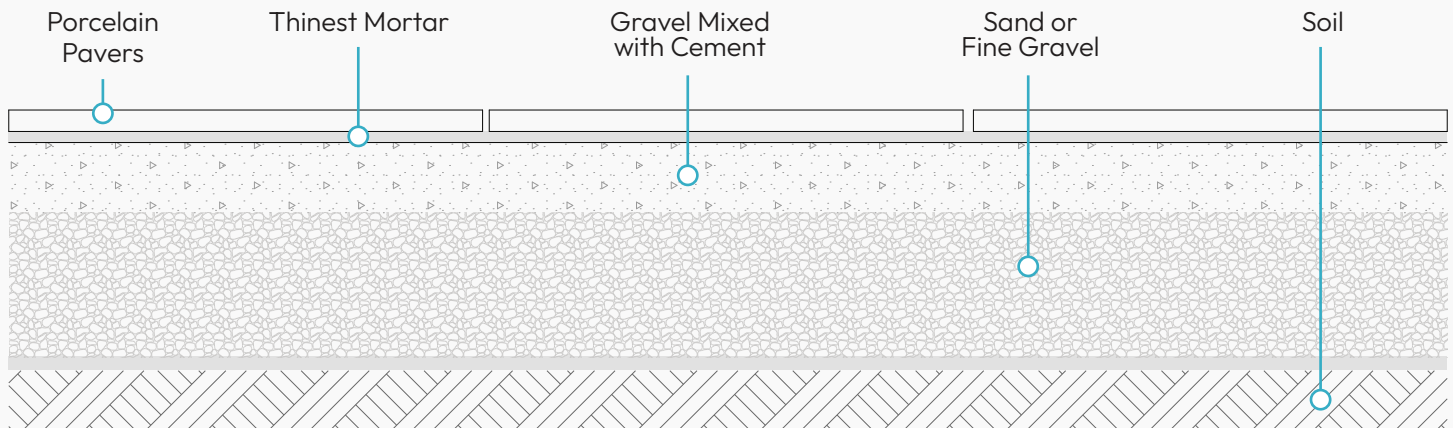

1. After defining the area to be excavated, mark the perimeter using wooden or steel marker posts connected by a string. Note that the excavated area should be extended on all sides by approx. 6"-8" to ensure stability at the outer edges of the paved area.
2. Remove the soil inside the marked area using a shovel or excavator. The depth of excavation will depend on several factors including the anticipated loading, the drainage capacity of the soil and the soil conditions in general.
3. Using a rake or shovel, level the excavated area and ensure there is at least 2% slope for good drainage. Compact the soil with a vibro compactor.
4. Fill the excavated area to a thickness of 8"-12" with a layer of sand or fine gravel, depending on the planned loading.
5. Compact the sand/gravel with a vibro compactor and ensure that the 2% approx. slope for drainage is maintained.
6. Mix gravel of size 3/16"-1/4" with 5% cement and a small amount of water and place over the compacted gravel layer to a thickness of 2"-4". Use a trowel to level the surface and if the joints between the pavers are not to remain as permeable, ensure there is slope of approx. 2%.
7. For optimum adhesion of the pavers to the bedding layer, specialized thinst mortar can be applied to the underside of the pavers.
8. Carefully tap the pavers with a rubber mallet to ensure they are bedded properly into the gravel/cement mix and that they are level with each other.

Installation - On Grade Applications

Over Concrete Base Set in Sand

Dry laying over an existing concrete slab is an alternative method to installing on fixed height rubber pads, which will ensure a quieter surface when walked on as well as providing enhanced load bearing capacity.

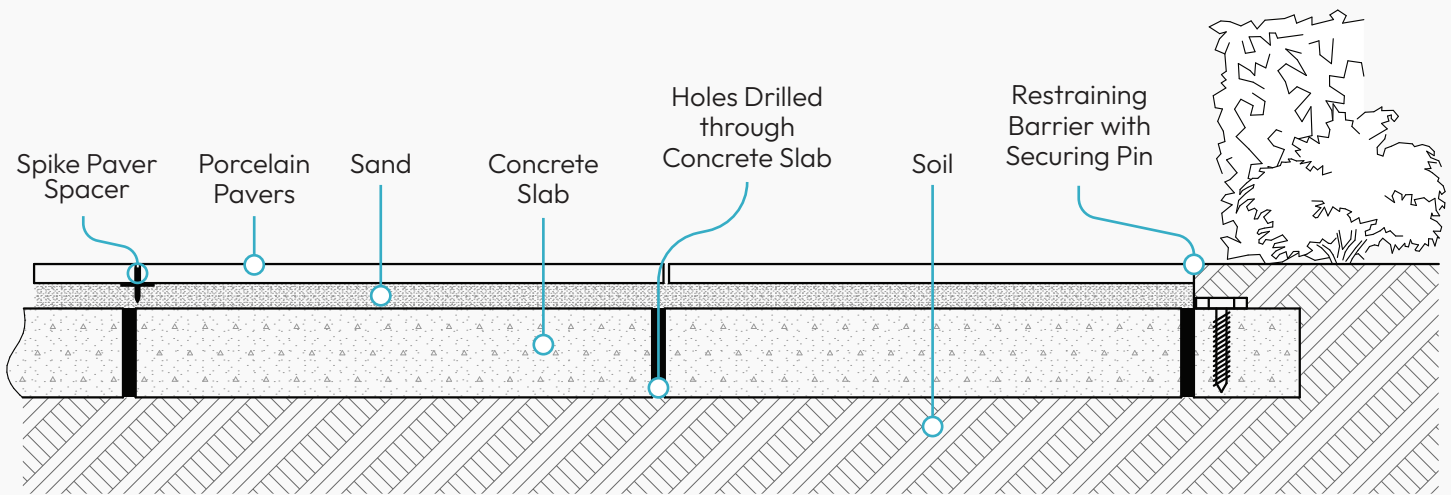

1. A restraining perimeter wall should be installed prior to laying the pavers unless it is in direct contact with a footpath, wall or an existing edge that is sufficiently rigid. The perimeter wall should be fixed to the concrete base with mechanical fixing devices or constructed as a solid barrier using poured concrete.
2. Drill $\frac{1}{2}$ " diam. drainage holes 24" on center through the concrete to provide additional drainage (if required).
3. Place a sheet of geotextile fabric on top of the concrete to contain the bedding sand. Fill the area with sand to a thickness of approx. 1" and compact with a vibro compactor.
4. Level the surface by sliding a wood or steel board placed on two parallel runners across the entire area, again ensuring there is a slope of approx. 2%.
5. Taking care not to disturb the sand bed, lay the pavers using $\frac{3}{16}$ " min. spacers. Carefully tap the pavers with a rubber mallet to ensure they are not rocking on the sand bed and that they are level with each other.

Installation - On Grade Applications

Over Concrete Base with Thinset or Adhesive

Recommended for driveways, car parking areas and other areas subject to light vehicular traffic. Ideal for creating continuity between pedestrian areas and vehicular access areas.

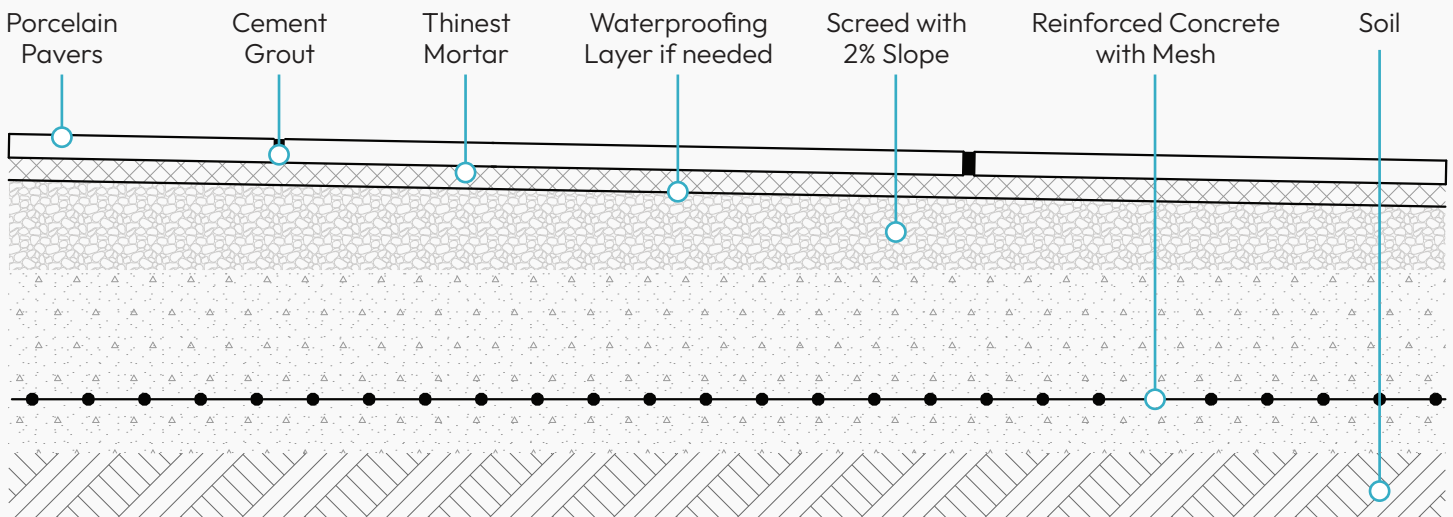

1. Verify the concrete substrate is in good condition, is installed in accordance with relevant building codes and reinforced with steel mesh and is constructed with approx. 2% slope pitched away from any building.
2. Clean the surface of the concrete well to ensure good adhesion of the pavers.
3. Spread an approved exterior grade thinset mortar over the concrete using the correct sized notched trowel.
4. Lay the pavers on the thinset with minimum 1/8" to 3/16" joint spacing where the area is not large enough to require expansion joints, or with 3/8" spacing where expansion joints are present. All expansion joints must be located along the joint line of the installed pavers to avoid cracking of the pavers. If a porcelain paver is installed over a control joint, the paver will eventually crack along the expansion joint beneath it.
5. After the thinset has dried, grout the pavers with an approved exterior grade grout. Wash the pavers carefully and thoroughly after grouting to remove excess grout.
6. A final buffered acid wash will also be required to remove any invisible grout residue.

Installation - On Grade Applications

Over Grass

This laying method for creating stepping stones, walkways, barbecue areas and gazebos in the garden avoids extensive excavation and site preparation.

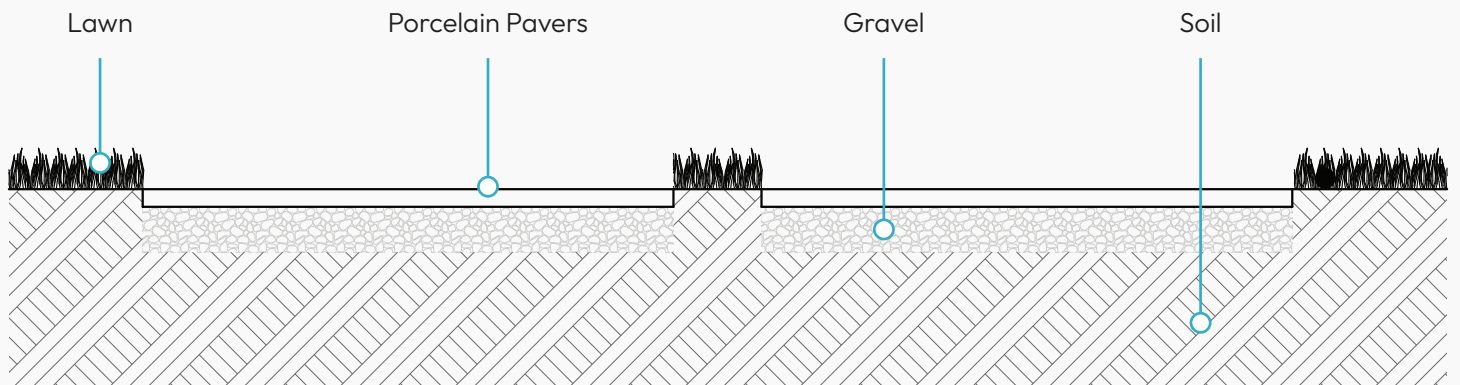

1. Lay the pavers on the ground to determine the number of steps needed for the garden path, making sure the pavers are placed at equal distance from each other.
2. The joint width between the pavers should be chosen depending on the appearance required. For stepping stones or pathways, the pavers would normally be laid with open joints with grass in between. However, for areas where outdoor furniture will be used, pavers would normally be laid with closed joints.
3. Mark the perimeter of each paver with a spade and then remove the pavers. Remove the turf up to a depth of 2"-3".
4. Fill with a layer of fine 3/16"-1/4" gravel and compact the gravel before laying the pavers. If preferred, lay a 1" thick layer of sand to add as a bed for the pavers.
5. Carefully lay the pavers so they protrude above ground level by about 1/4". The pavers must not protrude above the lawn level, to avoid damaging lawnmower blades when cutting the grass.
6. Carefully tap the pavers with a rubber mallet to ensure they are bedded properly.

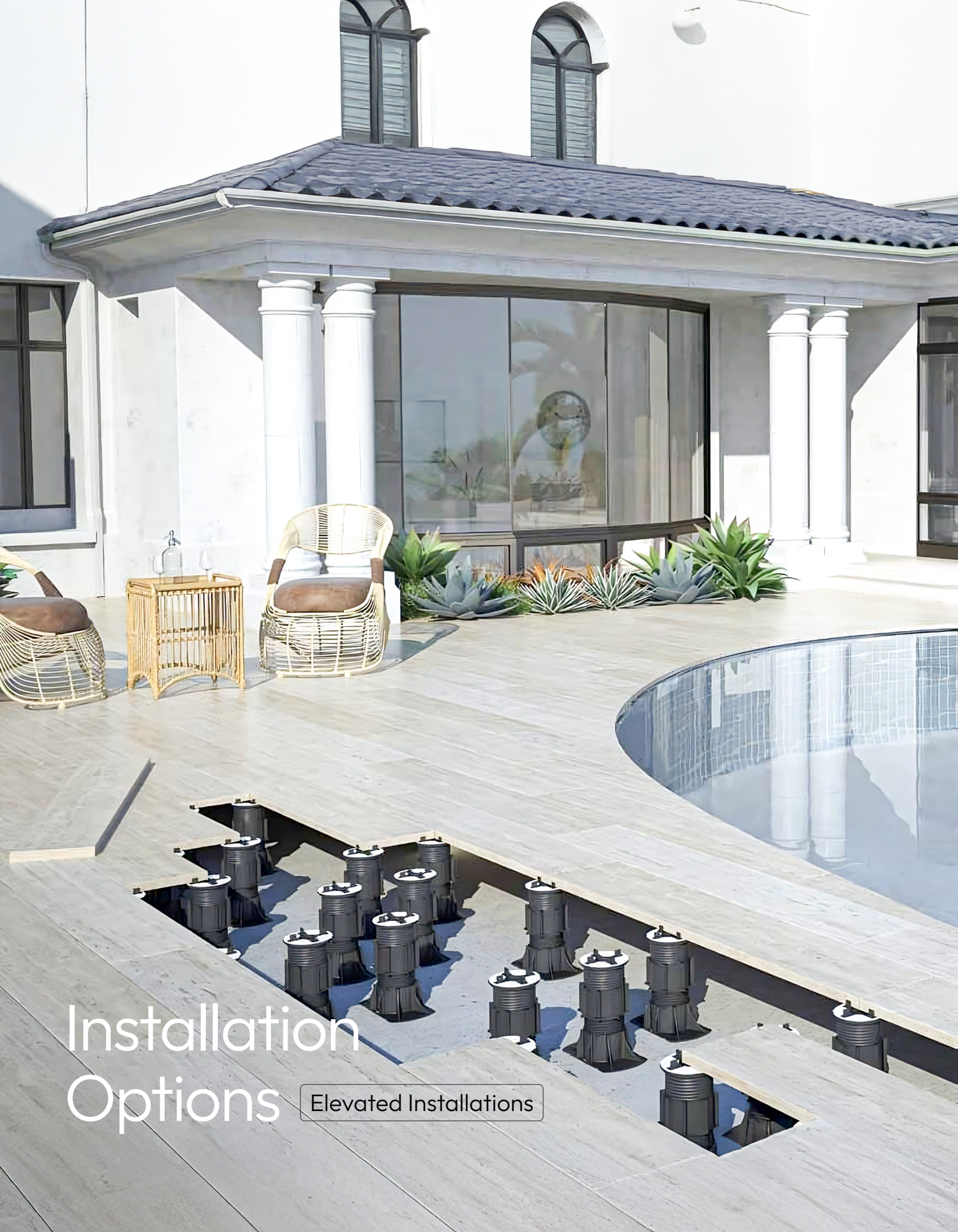

Installation Options

Elevated Installations

Installation - Elevated Applications

Stackable Rubber Pads over Hard Surfaces

A quick and easy method for laying pavers over existing concrete or other hard surfaces which may be removed and replaced at will.

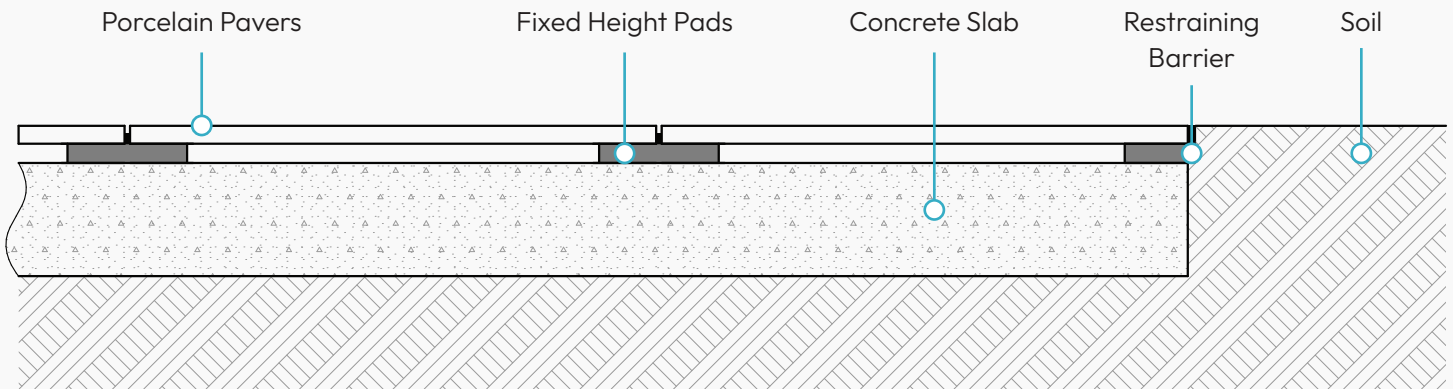

1. The substrate should be as even as possible, although pads can be laid over cracked concrete provided they are not placed directly over any cracks. There should be approx. 2% slope pitched away from any building for drainage.
2. The paved area should be bounded fully by a containment barrier or other restraining device to ensure the pavers do not move. However, with rubber fixed height support pads, the extra friction of these pads compared with plastic pads may be sufficient in some circumstances to avoid the need for a restraining barrier.
3. Draw the proposed layout of the pads on the concrete using chalk and optimize the placement of the pads and pavers to avoid having cut sections of pavers at any point around the perimeter less than 8" wide.
4. Along straight lengths of the perimeter, cut pads in semicircles and place them with the cut sides flush with the perimeter edge pads which have been cut in semicircles along the perimeter at the paver intersections, ensuring the only remaining spacer tabs are aligned with the gap between pavers. At right angle corners, cut pads into quadrants with all spacer tabs removed and place in corners.
5. Place pavers carefully over the rubber pads ensuring each paver butts tightly against the spacer tabs.
6. Use 1/16" or 1/8" thick shims between the paver and pads as required to adjust for any slight unevenness of the substrate.
7. Fixed height pads may be stacked on top of each other up to heights of approx. 1 1/2" providing the opportunity to create a paved area that is perfectly level and horizontal irrespective of any slight slope of the substrate.

Tab removal at perimeter

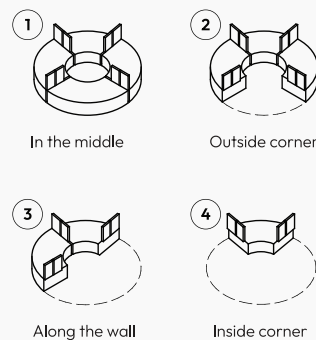

Placement of fixed height pads around perimeter walls

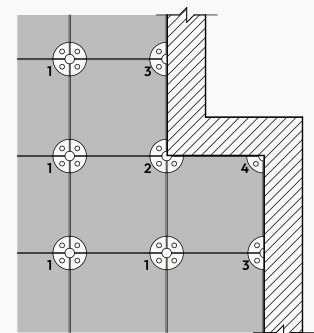

Installation - Elevated Applications

Adjustable Height Pedestals over Hard Surfaces

A pedestal paver system is the most convenient and cost-effective method of building rooftop decks and elevated exterior floors over sloping or uneven substrates and is most useful for covering electrical cables and service pipework.

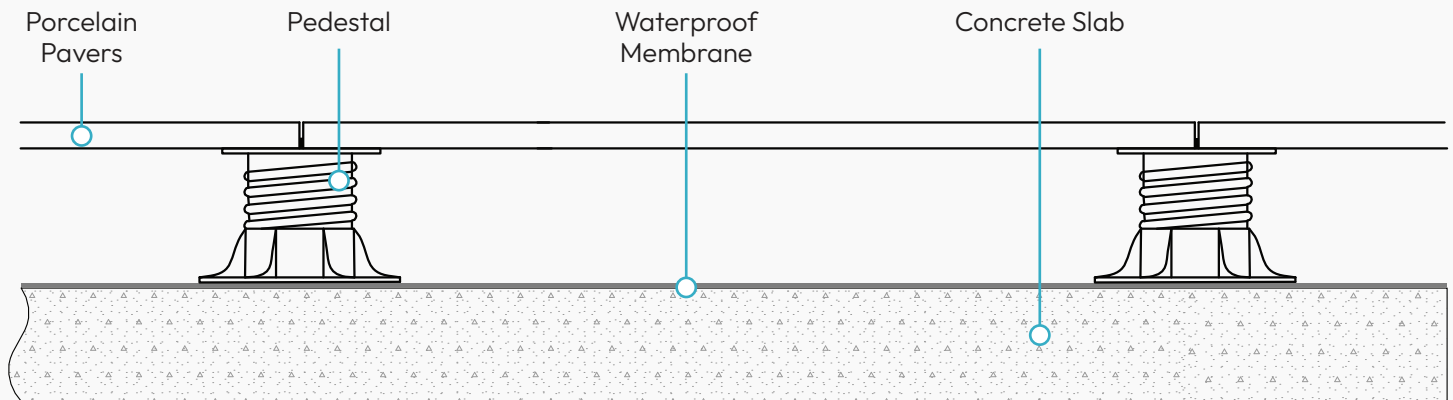

1. Ensure the substrate is smooth and even across the surface and constructed with a minimum 2% slope to drainage points.
2. The paved area should be bounded fully by a containment barrier or other restraining device to ensure the pavers cannot move.
3. Use sight or laser lines to mark the intersections of the corners of each paver to be laid.
4. Draw the layout of the pedestals on the concrete using chalk and optimize the placement of the pavers to avoid cuts which would leave sections less than 8" wide. With 24" x 24" pavers, one pedestal is situated at each intersection of 4 pavers in the body of the deck and at where adjacent pavers meet around the perimeter. Depending on the proposed application, an additional pedestal may be required under the center of each paver, in which case, all spacer tabs should be snapped or cut off from the pedestal head.
5. Archatrak 'Prime' pedestals feature self-adjusting heads which automatically compensate for slopes up to 5%. If non self levelling pedestals are used, slope correction rings or other add in slope compensators will need to be used to ensure the pavers are level with the pedestal heads.
6. Position the first pedestal in one corner of the area and place subsequent pedestals along a wall edge, spaced according to the width of the pavers to be used. With Archatrak 'Prime' pedestals, place the cut side of the base against the wall. Other pedestals without a pre-cut base will need the bases trimmed to ensure the pedestals are situated as close as possible to the wall. Snap off tabs on the heads as required.
7. Place a second row of pedestals parallel to the first and separated from the first row by the width of the pavers.
8. Place the pavers with each corner resting on the top of each pedestal.
9. Screw the head component up or down to ensure each paver is level. The surface should be checked for level as each row of pavers is laid.
10. If necessary, install quadrants of rubber shims between the pavers and the head to correct the height of any paver and to prevent any rocking.

Placement of variable height pedestals around perimeter walls

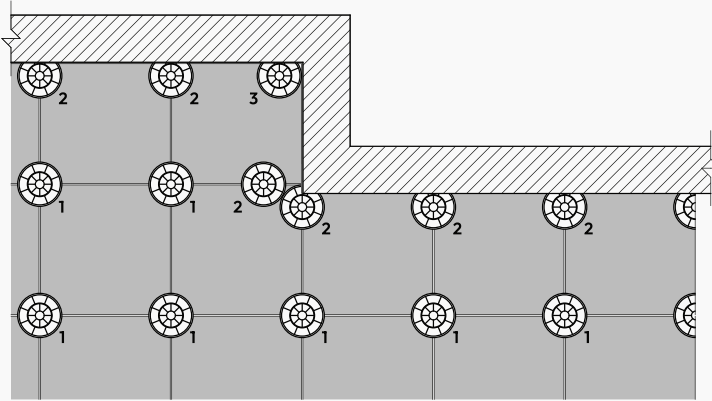

Tab removal at perimeter

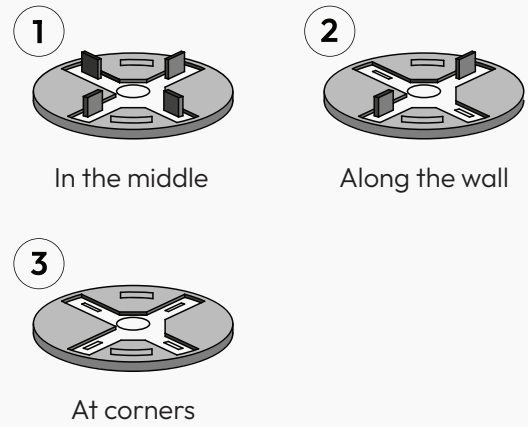

Pedestal placement for different sized pavers and laying configurations

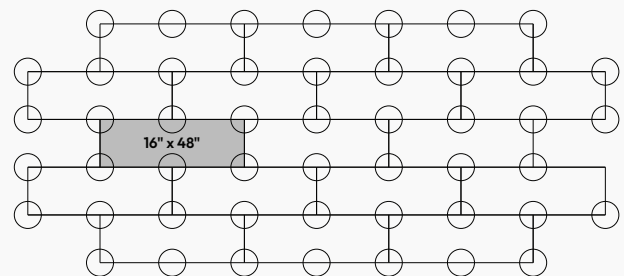
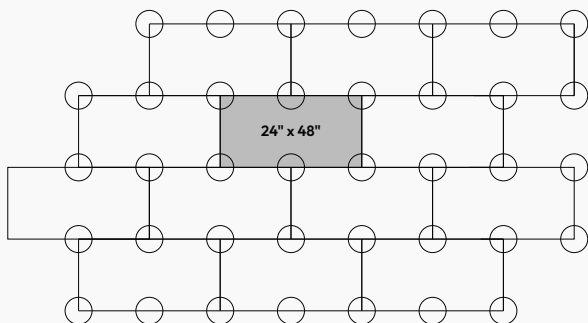
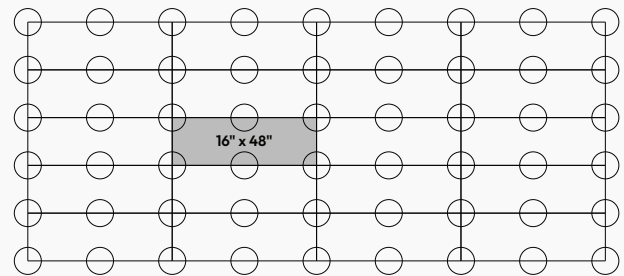
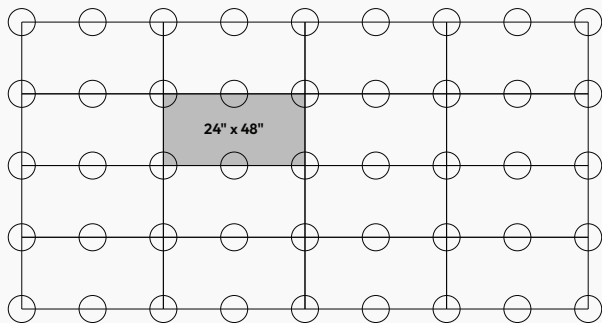

Installation - Elevated Applications

Pedestal Supported Rail System

A pedestal supported rail system is typically used when building an elevated deck on a rooftop or balcony with porcelain pavers less than 16" wide. It provides the best paver support, most efficient use of pedestals and easier paver levelling. The aluminum rails are clipped onto specially designed pedestal heads. A rubber strip is run along the top surface of the rails to minimize noise transmission. Porcelain planks are then laid over the rails, separated by spacer tabs slid along a channel in the rails.

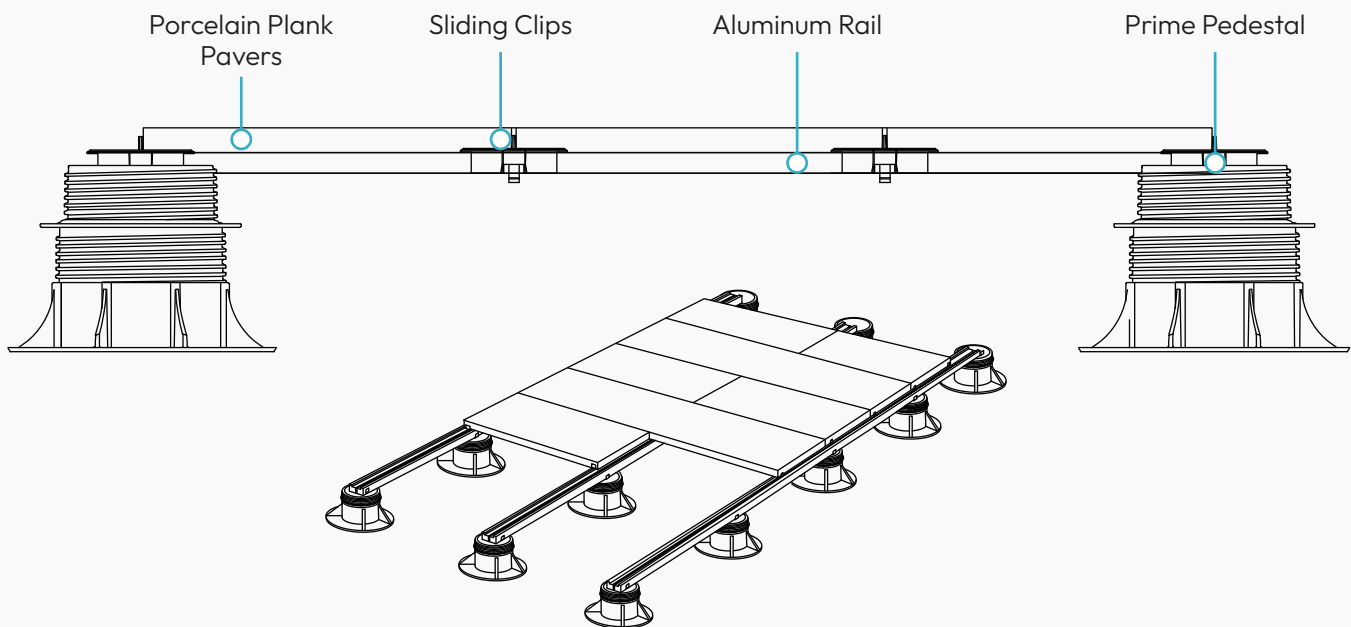

1. Ensure the substrate is smooth and even across the complete surface and constructed with a minimum 2% slope to drainage points.
2. The paved area should be bounded fully by a containment barrier or other restraining device to ensure the pavers cannot move.
3. Lay out pedestals in an array with spacing in both directions determined by the width of pavers to be used and the expected traffic loading. (contact Archatrak support for further details)
4. Lay the first rail onto the head of the pedestal at each end of the rail, pushing it down firmly to securely clip the rail to the head. Check for level.
5. Clip the remaining pedestals situated under the rail onto the heads, adjusting the pedestal heights to ensure they sit tightly on the substrate and that the entire rail assembly is stable.
6. Add extra lengths of rail as required to the end of the first rail using the special plastic connectors.
7. Lay the remaining rails in the same manner and parallel to the first row, checking constantly for level across the parallel rails.
8. Lay the porcelain planks over the rails using sliding spacer tabs to correctly space the planks.

Special Considerations with Elevated Decking Installations

Project managers, specifiers and customers should carefully assess the intended use of porcelain pavers in elevated decking applications in relation to their specific technical specifications and properties.

Any outdoor paving materials installed above the ground level without adhesives or other secure fixing devices will be subject to the action of wind, with the risk in some cases of becoming airborne. Archatrak recommends obtaining the assistance of qualified personnel to confirm the suitability of the installation system for aboveground application both in accordance with the intended conditions of use and compliance with any local laws and regulations, including regulations relating to seismic events and hurricanes.

The shock resistance of porcelain pavers must also be considered with pedestal installations to avoid the risk of damage or injury. Despite the intrinsic density and stiffness of porcelain pavers, a porcelain paver installed on a raised pedestal system may break if a heavy object is dropped on it. Where hard and heavy objects are likely to be used or where floor heights are greater than 4", appropriate reinforcement such as glued fiberglass mats or metal trays should always be applied to the underside of the pavers, or the pavers laid over fiberglass grating panels.

Archatrak supplies self-adhesive fiberglass reinforced sheets, pre-cut to cover the underside of 24" x 24" or 16" x 48" (nom.) pavers, galvanized steel plates to suit 24" x 24" or 16" x 48" pavers, and 96" x 48" fiberglass grating panels which can be installed under porcelain pavers of all dimensions.



Warning

FAILURE TO COMPLY WITH THESE RECOMMENDATIONS COULD LEAD TO IMPROPER USE OF THE PRODUCTS AND COULD CAUSE SERIOUS DAMAGE TO PROPERTY OR INJURY.



Get in Touch with Us Today!

We're here to help! Reach out with any questions and our team will get back to you as soon as possible.

 www.archatrak.com

 866 206 8316

 solutions@archatrak.com