

Archatrak Structural Ipe Wood Tiles

Prefabricated, structural grade wood tiles constructed with 13/16" Ipe wood slats screwed to three solid wood support battens using stainless steel screws. Tiles are supplied without any preservative coating apart from waxed board ends.

- No bearers or steel supporting structure needed.
- Hard wearing and scratch resistant.
- Highly resistance to termites, decay and mold.
- Tiles weather without splintering .
- Available in 24" x 24" and 48" x 24" sizes.

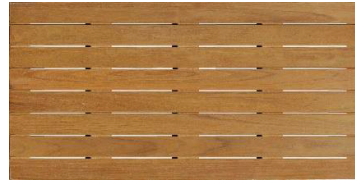

48" x 24"

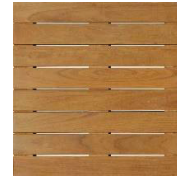

24" x 24"

STRUCTURAL IPE WOOD

Specifications

PROPERTY	IPE WOOD TILES	PRODUCT CODES & SIZING
Finish	Smooth	Ipe Tiles TILE-IPE-48SMTH-8SL596 23 7/16" x 47" TILE-IPE-24SMTH-8SL596 23 7/16" x 23 7/16"
Overall Height	1 11/16"	
Slat thickness	13/16"	
Width of slats	2 7/8"	
Slats per tile	8	
Slat spacing	3/16" approx..	
Screws	Stainless steel	
Ends & sides finish	S4S E4E (radius 1/8")	
Surface treatment	Raw - uncoated	
Weight	6 lb/sq.ft approx.	
Warranty	3 years	

Ipe Wood Properties

Density	64 lb/ft ³
Durability	Class 1 (min. 25 years life)
Hardness (Janka)	3680 (very hard)
Decay resistance	1 (very resistant)
Modulus of rupture	22,600 psi
Modulus of elasticity	21,600 MPa
Crushing strength	13,000 lbf/in ²
Shrinkage	7% tangential, 6% radial

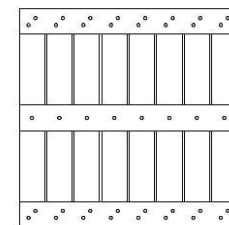
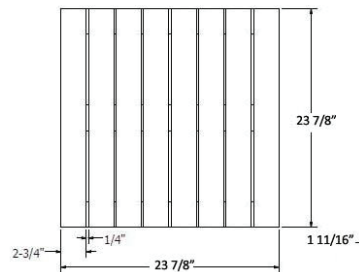

TILE-IPE-DT2424-FSC

Testing

PROPERTY	STANDARD	RESULT
Concentrated load on pedestals	ASTM E2322-03	3515 lbs
Uniform load on pedestals	ASTM E2322-03	2901 lbs
Solar Reflectance Index - New	ASTM E1980-11	41
Solar Reflectance Index - Weathered	ASTM E1980-11	24
Fire - Flame Spread	ASTM E108-07	Class A
Fire - Intermittent Flame	ASTM E108-07	Class A
Slip Resistance	ASTM E303-22	Dry 67, Wet 28

Surface Finish

Archatrak Ipe wood tiles are manufactured using 'A' grade lumber which, in accordance with standard industry classification, permits some knots, color variation, dark streaks, pin holes, checking etc. Decking timber is not furniture grade.

Tiles are supplied in a natural, unfinished state. It is highly recommended that a good quality decking oil is applied as soon as practical after installation, which not only assists in maintaining the color as long as possible, but also provides some protection from airborne particles which can leave dark spots or markings on unfinished timber.

To provide good drainage under the tiles, the surface should normally slope slightly away from the outer wall of any structures.

Wax Treatment of Slat Ends

Archatrak structural Ipe wood tiles are not supplied with any factory applied oil coating. However, in accordance with normal industry practice, a wax material is applied to the ends of the slats to reduce the possibility of end checking. Be aware that this wax can 'bleed' a short distance along the top surface of the slats after installation, especially when the tiles are exposed to hot, sunny conditions and when the tiles have not been coated with a good quality decking oil after installation. There can often be a significant color contrast between the partially weathered body of the tiles and the wax impregnated ends, appearing as if the ends of the slats have been saturated with water.

Although this phenomenon should disappear over time as the tiles weather naturally, we nevertheless strongly recommend applying a good quality decking oil as soon as practical after installation to reduce the potential for 'bleeding' and reduce the rate of fading to a silvery grey. Even when some weathering has occurred, some wax can remain in the pores of dry wood, effectively providing some waterproofing to the ends of the slats, manifesting as a difference in color between the wax impregnated tile ends and body of the slats when the tiles are wet.

Pedestal Installation

Archatrak Ipe wood tiles are specifically designed for installation on pedestal supports for constructing elevated decks. Any installation should ensure good air circulation can be maintained under the tiles and that the tiles will not be subject to prolonged contact with water.

Solid edge restraint is required on all sides of the deck and all tiles must be butted as tightly as possible against tabs on pedestal heads. Ensure there is no space exceeding 3/16" between the edge of the tiles and the restraining walls on all sides of the deck.

Ipe Tile Transition to Porcelain Paver

Archatrak Ipe wood tiles are the same dimension as the majority of our 2cm thick porcelain pavers and may thus be installed alongside each other without the problem of paver gaps becoming misaligned as you proceed laying across the deck area. The pedestals just need to be adjusted in height to compensate for the different tile and paver thickness. With Archatrak Prime pedestals, the cut sides of the base of adjacent pedestals should be positioned facing each other.

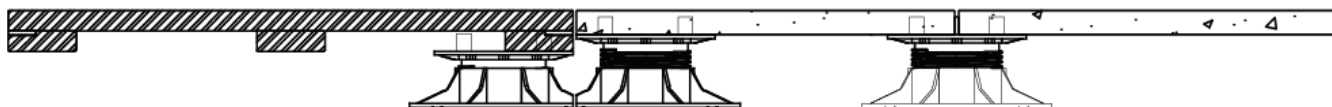

Cutting

If any tiles need to be cut, make sure to remove any screws that fall in the path of the proposed cut. With any cut tile, it is very important that the structural integrity of the tile is maintained. This may require relocating one (or two) of the support battens and re-attaching these to the slats from the underside of the tile. It may also be necessary to drill and countersink additional holes when re-inserting screws.

To minimize checking or cracking at the need of cut slats, apply an appropriate sealer to the cut ends. Make sure not to get any sealer on the surface of the tiles to prevent any color differences between sealed and unsealed surfaces.

Wind Uplift Considerations

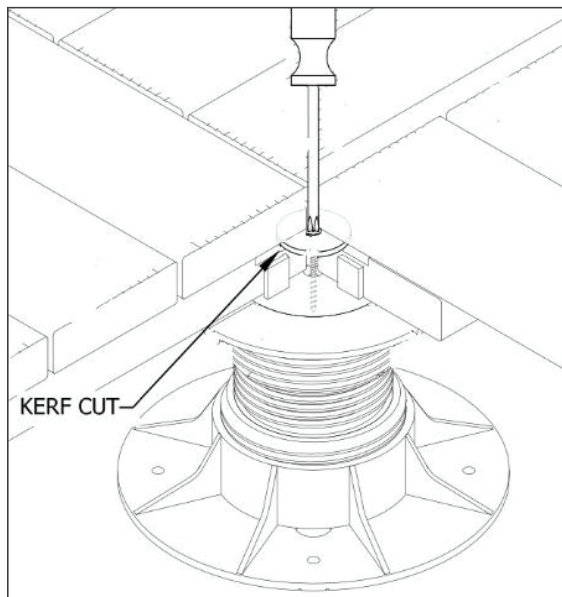

Testing undertaken by Archatrak at the Florida International University Hurricane Research Center indicated that blow off of Archatrak 24" x 24" Ipe wood tiles installed on fixed height pedestals with a 12" parapet did not occur until wind speeds reached 130 mph.

Nevertheless, for additional security, Archatrak structural wood tiles are constructed with a slot cut in each corner enabling a special screw and washer component (ETE-IPE-SCREW) to be inserted in the slot and invisibly screwed to the top of the pedestal without damaging the wood surface, to "lock down" the tiles to the pedestal.

Place the pedestal under two adjacent pavers and level the pavers using the adjustment tool.

Move the pedestal slightly towards you and insert the fastening screw into the hole in the center of the pedestal head.

Using a Pozidriv #2 bit (not a Philips bit) turn the screw until the washer is level with slot cut in the tiles. Push the pedestal back towards the tiles so the tabs on the head butt firmly against the tiles and the washer engages the slots.