



ARCHASOL

ARCHASOL
1288 N 14TH AVE. UNIT 105
BOZEMAN, MT 59715
PHONE: (406) 551-7955
www.archasol.com

SELECT DESIRED POWDERCOAT COLOR:

- RAL 7016 - ANTHRACITE GREY
- RAL 7011 - IRON GREY
- RAL 7030 - STONE GREY
- RAL 9001 - CREAM WHITE
- RAL 8017 - CHOCOLATE BROWN

SELECT DESIRED CUSTOMIZATION OPTIONS:

- WIFI MODEM
- PARTICULATE MATTER SENSOR: PM1, PM2.5, PM10
- GAS SENSOR: NO, NO₂, O₃
- PLANTER WITH MOISTURE SENSOR
- HYBRID MODULE WITH CONNECTION TO GRID POWER
- LCD DISPLAY (HYBRID MODEL ONLY)
- AI/ML LCD DISPLAY WITH AI CAMERA (HYBRID MODEL ONLY)

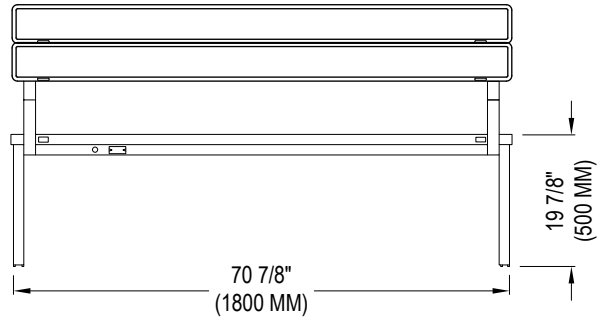

FRONT VIEW

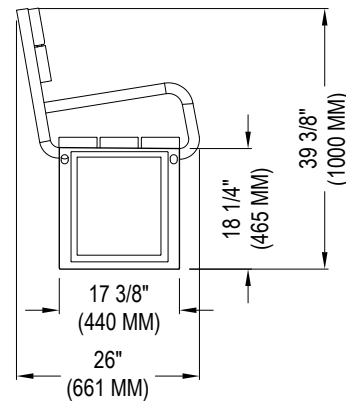

SIDE VIEW

TECHNICAL SPECIFICATIONS:

PHOTOVOLTAIC PANELS: 165 W OUTPUT - IK08 - VANDAL RESISTANT

BATTERY: LI-ION - 190 Wh

PHONE CHARGING OUTLETS: 2 X Qi, 4 X USB

SENSORS: PARTICULATE MATTER, GAS

CONTROLLER: REMOTE VIA SOLOS SOFTWARE

LIGHTING: AMBIENT UNDER BENCH

NOTES:

1. INSTALLATION TO BE COMPLETED IN ACCORDANCE WITH MANUFACTURER'S SPECIFICATIONS.
2. DO NOT SCALE DRAWING.
3. THIS DRAWING IS INTENDED FOR USE BY ARCHITECTS, ENGINEERS, CONTRACTORS, CONSULTANTS AND DESIGN PROFESSIONALS FOR PLANNING PURPOSES ONLY. THIS DRAWING MAY NOT BE USED FOR CONSTRUCTION.
4. ALL INFORMATION CONTAINED HEREIN WAS CURRENT AT THE TIME OF DEVELOPMENT BUT MUST BE REVIEWED AND APPROVED BY THE PRODUCT MANUFACTURER TO BE CONSIDERED ACCURATE.
5. CONTRACTOR'S NOTE: FOR PRODUCT AND COMPANY INFORMATION VISIT www.CADdetails.com/info AND ENTER REFERENCE NUMBER 5501-003.

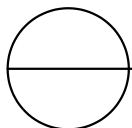

SOLAR SEATING - SEAT TOP PV CELLS

STEORA 'CITY' SOLAR BENCH WITH BACKREST