

SELECT DESIRED HEIGHT:

PR1 - 1 3/16" - 2 1/2"

PR2 - 2 1/16" - 6"

PR3 - 6" - 16 1/2"

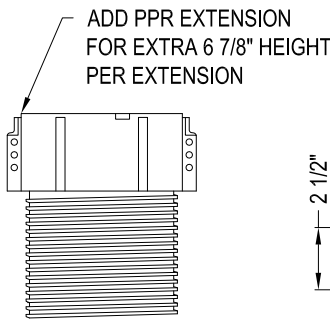
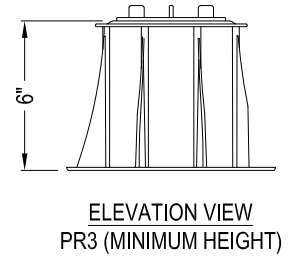
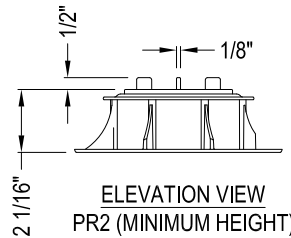
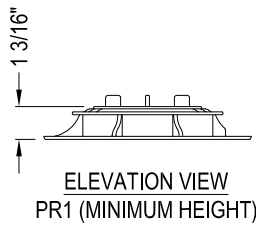
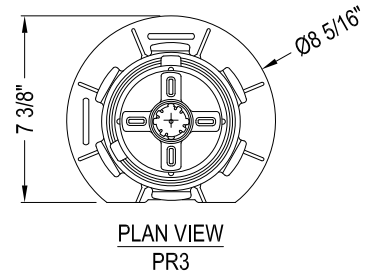
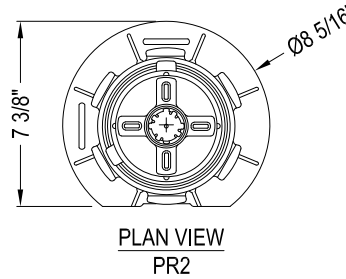
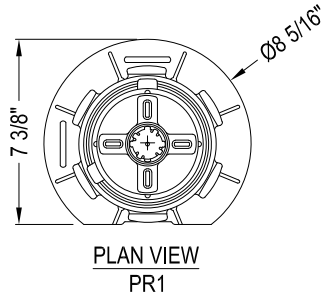

DETAIL
PPR EXTENSION

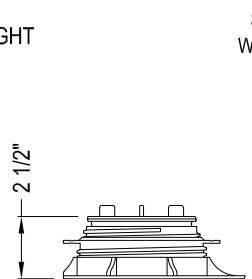

ELEVATION VIEW
PR1 (MAXIMUM HEIGHT)

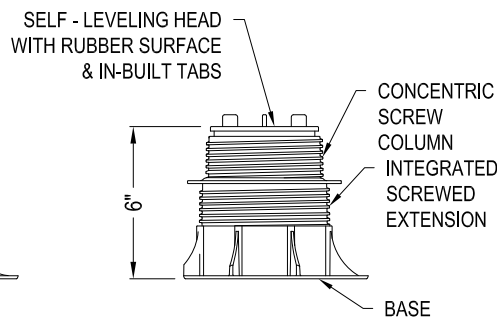

ELEVATION VIEW
PR2 (MAXIMUM HEIGHT)

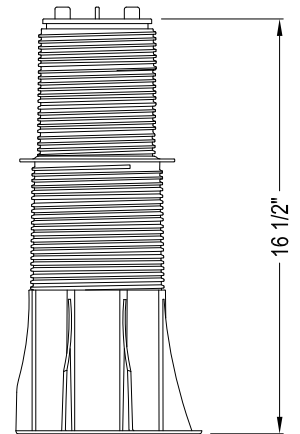

ELEVATION VIEW
PR3 (MAXIMUM HEIGHT)

GENERAL NOTES:

1. INSTALLATION TO BE COMPLETED IN ACCORDANCE WITH ARCHATRAK SPECIFICATIONS.
2. DO NOT SCALE DRAWING.
3. THIS DRAWING IS INTENDED FOR USE BY ARCHITECTS, ENGINEERS, CONTRACTORS, CONSULTANTS AND DESIGN PROFESSIONALS FOR PLANNING PURPOSES ONLY AND SHOULD NOT BE USED FOR CONSTRUCTION.
4. ALL INFORMATION CONTAINED HEREIN WAS CURRENT AT THE TIME OF DEVELOPMENT BUT MUST BE REVIEWED AND APPROVED BY ARCHATRAK TO BE CONSIDERED ACCURATE.

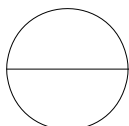

ADJUSTABLE HEIGHT PAVER SUPPORTS

ETERNO 'PRIME' SERIES PAVER SUPPORTS